

i960[®] KA/KB 32-Bit Embedded Microprocessors

Product Overview

The i960[®] KA/KB embedded RISC processors were introduced in 1988 as the first members of the Intel i960 32-bit microprocessor family. They are based on the family's high-performance, common core architecture and are capable of execution rates in excess of 9.4 MIPS. The i960 KA/KB processors are well-suited for a wide range of embedded applications, including page printers, image processing, industrial control, robotics and telecommunications products.

The i960 KB processor is pin-compatible with the i960 KA processor and integrates an IEEE 754 compatible floating point unit. The i960 KA/KB processors are object code-compatible with all of the i960 microprocessor family members, including the low-cost i960 SA/SB processors; the superscalar i960 CA/CF processors; and the military i960 MC processor, enabling a strong growth path in both performance enhancement and cost reduction.

Product Highlights:

- High-Performance 32-bit Embedded Architecture
- 512-byte Direct Mapped Instruction Cache
- 4 Gigabyte, Linear Address Space
- Multiple Register Sets with Register Scoreboarding
- Built-in Interrupt Controller
- Built-in IEEE 754 Compatible Floating Point Unit (i960 KB processor only)
- Available in 16, 20 and 25 MHz

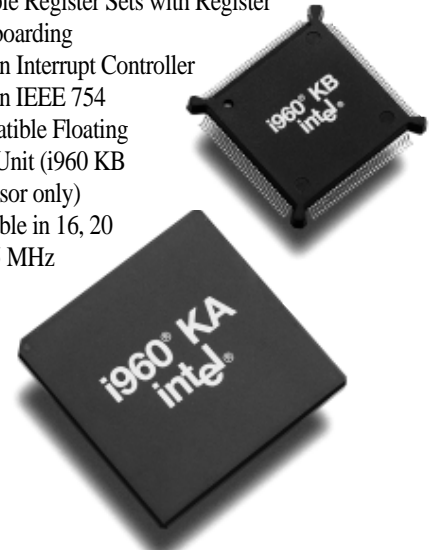

The i960[®] KA and i960 KB processors are available in 132-lead Pin Grid Array (PGA) and 132-lead Plastic Quad Flat Pack (PQFP) packages.

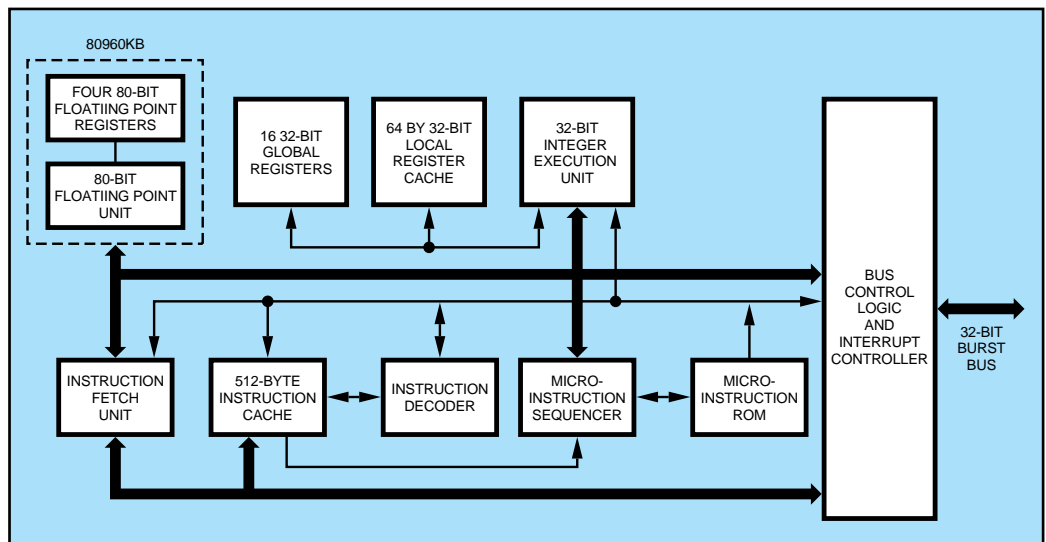

i960[®] KA/KB Microprocessor Block Diagram

Features

- High-Performance 32-bit RISC Processor
 - 25 MIPS burst
 - 9.4 MIPS sustained
- Integrated Interrupt Controller
 - 4 direct interrupt inputs
 - 256 interrupt vectors
 - 32 priority levels
 - 8259A support
- 32-bit Address Space
- Integrated FPU (i960 KB processor only)
 - Full IEEE 754 Compatible
- Integrated 512-byte Instruction Cache
 - Direct mapped
 - Parallel load/decode for uncached instructions
- Large Register Set
 - 16 32-bit Local registers
 - 16 32-bit Global registers
- Integrated 256-byte Register Cache
 - Four local on-chip register sets
 - Register scoreboarding
- Object-code Compatible with other i960 Products such as the i960 SA/SB and the i960 CA/CF processors.
- System Level Testing
 - ONCE Mode
 - Integrated debug and tracing
- Integrated Self-Test
- Full Solutions960™ Program Support Including:
 - Evaluation Board Debug Tools
 - C Compiler Operating Systems
 - Assemblers Support Components
- Complete Technical Services

Benefits

- Brings high performance to your design.
- Reduces board level costs by reducing chip count.
- Offers flexibility in memory mapping peripherals and memory components.
- Provides high speed arithmetic without additional parts.
- Fast execution for critical routines.
- Fewer memory accesses means faster execution.
- Fast context switching for critical routines.
- Offers a strong growth path and cost reduction path for the future.
- Makes testing and debug of surface mount systems possible using ICE™ In-Circuit Emulator.
- Aids in assuring system reliability.
- Provides a complete development environment from hardware debug to software development and debug.
- Helps you get to market sooner.

Support Information

Product and Sales Information	Intel product information, sales office and distributor phone numbers.	800-628-8686
Literature Department	To order Intel product literature.	800-548-4725
Development Tools Hotline	Technical applications support for Intel development tools.	800-843-4481
FaxBack Service	Automated response system that faxes Intel documents to your fax machine at no cost. For a listing of all i960 micro-processor documents, order FaxBack service document #2068.	800-628-2283
Applications Bulletin Board Service	24-hour access via modem to publicly available technical information. For a complete listing of all files available on BBS, call the FaxBack service and request catalog #6 (BBS Master File Listing).	916-356-3600

Phone numbers listed above are for U.S. and Canada only.

UNITED STATES

Intel Corporation
2200 Mission College
Boulevard
P.O. Box 58119
Santa Clara, CA 95052-8119

JAPAN

Intel Japan K.K.
5-6 Tokodai, Tsukuba-shi
Ibaraki, 300-26

FRANCE

Intel Corporation S.A.R.L.
1, Rue Edison, BP 303
78054 Saint-Quentin-en-
Yvelines Cedex

UNITED KINGDOM

Intel Corporation (U.K.) Ltd.
Pipers Way
Swindon
Wiltshire, England SN3 1RJ

GERMANY

Intel GmbH
Dornacher Strasse 1
85622 Feldkirchen/
Muenchen

HONG KONG

Intel Semiconductor Ltd.
32/F Two Pacific Place
88 Queensway
Central

CANADA

Intel Semiconductor of
Canada, Ltd.
190 Attwell Drive, Suite 500
Rexdale, Ontario M9W 6H8

Intel corporation assumes no responsibility for the use of any circuitry other than circuitry embodied in an Intel product. No other circuit patent licenses are implied. Information contained herein supersedes previously published specifications on these devices from Intel.

*Other brands and names are the property of their respective owners.

©Intel Corporation 1994

January 1994

Order Number 272233-003

Printed in U.S.A./i960-282.0/0194/10K/HP DP

 Printed on Recycled Paper

intel®